

NUMBER 59275

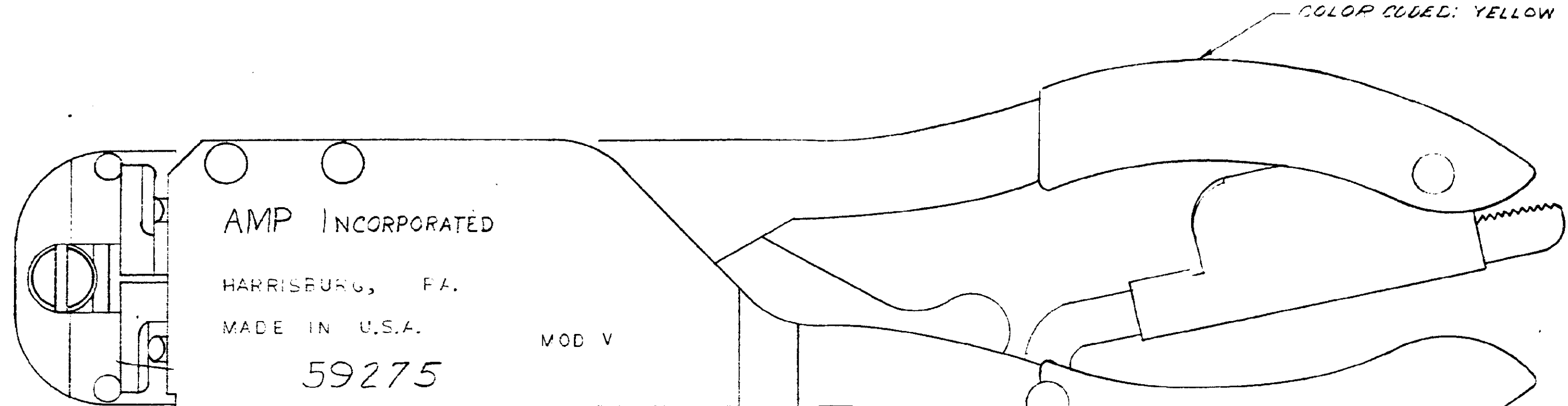

NOTE:
 1. WHEN PLUG OR SLUG GAGING OF BARREL CRIMP IT IS IMPORTANT TO NOTE THAT DIMENSION "A" IS THE FIGURE REQUIRED
 PLUG GAGE DIMENSIONS APPLY WHEN TOOL IS BOTTOMED BUT NOT UNDER PRESSURE.

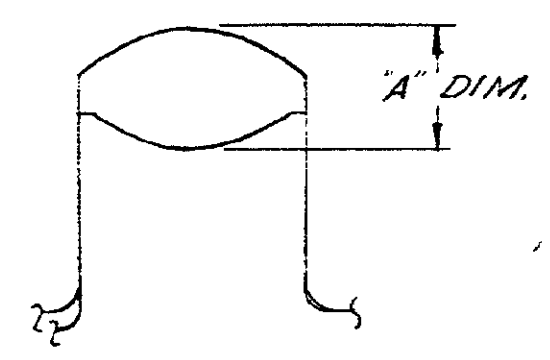

BARREL - CRIMP

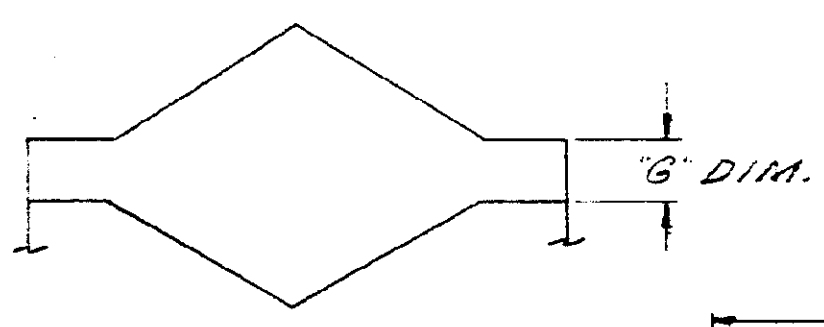

INSULATION - CRIMP

ENLARGED VIEW OF CRIMPS

WIRE SIZE	"A" DIA.		"G" DIM.	
	BARREL CRIMP	INSUL. CRIMP	BARREL CRIMP	INSUL. CRIMP
GAGE	GO	NC GO	GO AT POS #1	NC GO AT POS #4
26-22	.063	.069	.025	.075
24-20	.089	.095	.035	.085

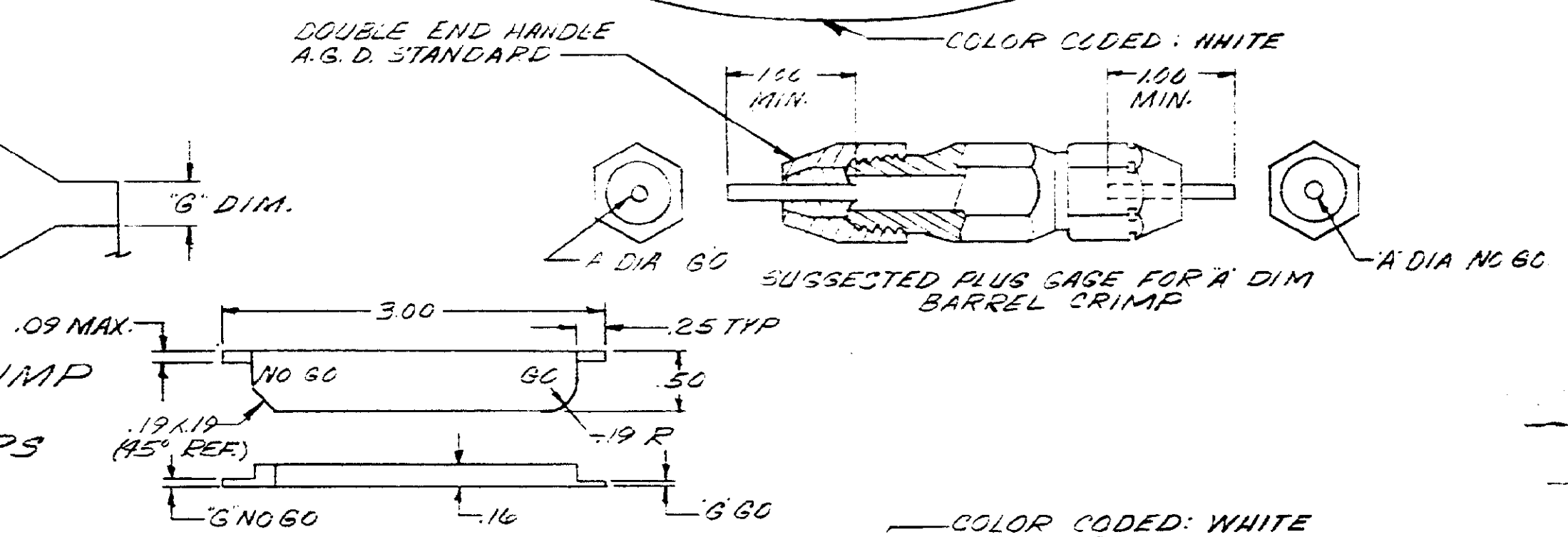

SUGGESTED PLUG GAGE FOR "G" DIM. INSULATION CRIMP

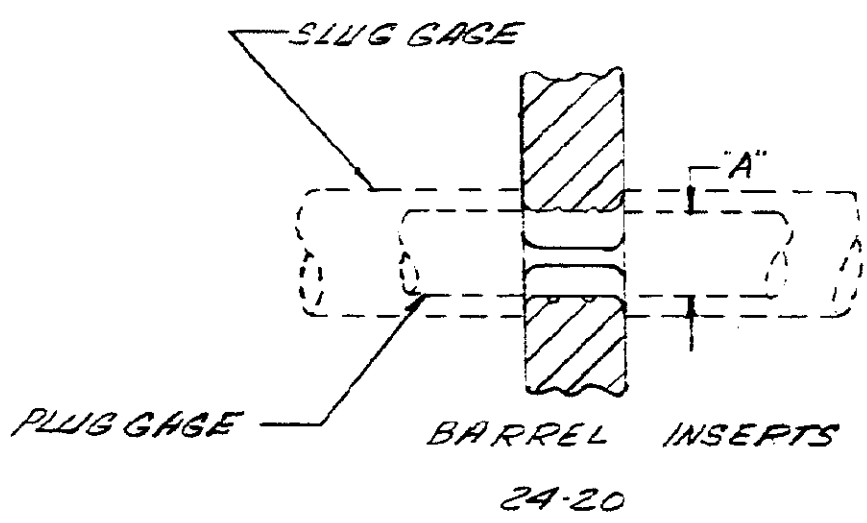

BARREL INSERTS

24-20

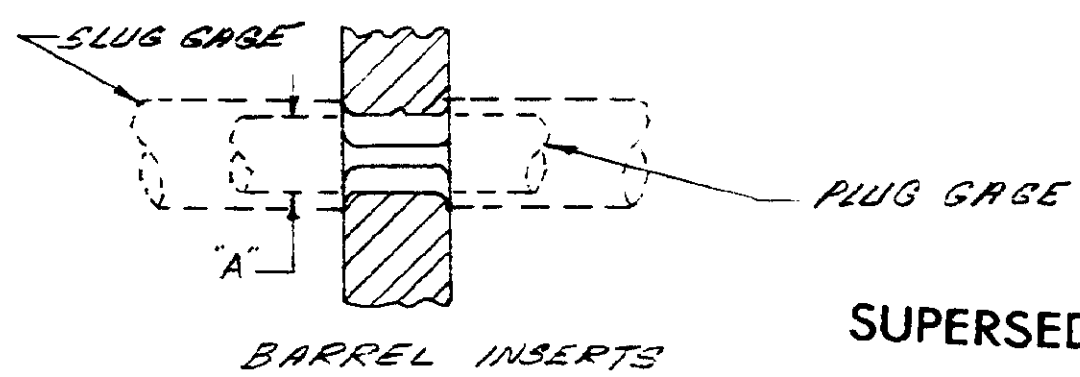

BARREL INSERTS

26-22

SUPERSEDED BY I.S. 1610

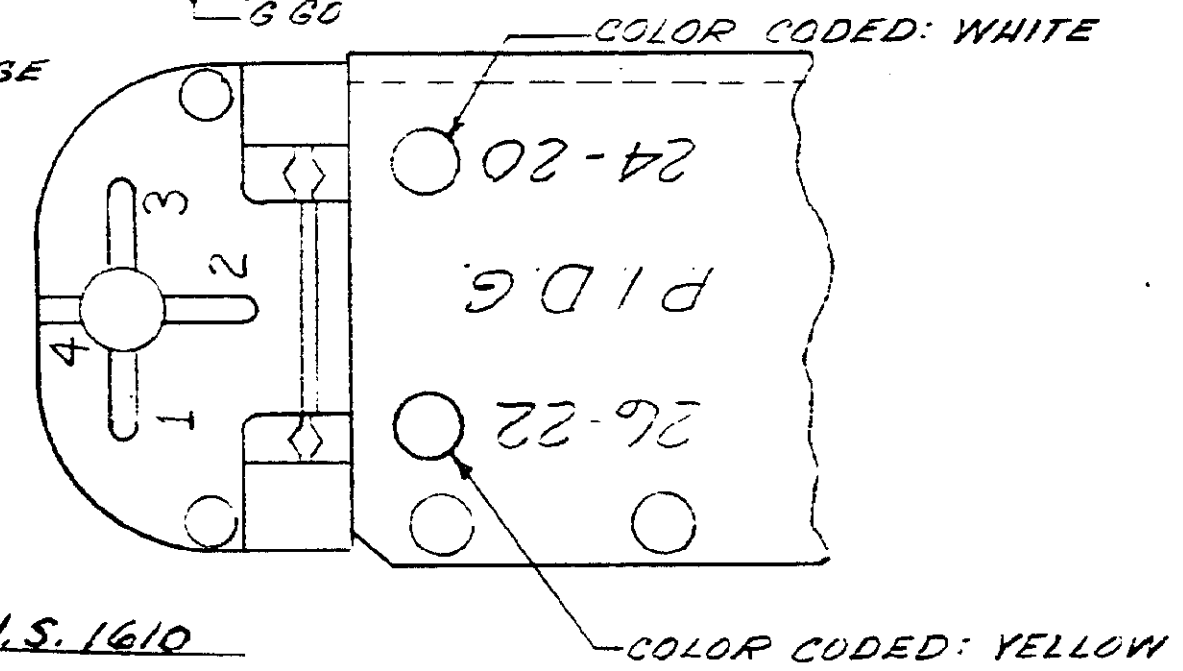

COLOR CODED: YELLOW

DIMENSIONS IN INCHES DO NOT SCALE PRINT

REV	DESCRIPTION	DATE
VI	SUB BY I.S. 1610	12-31-62
V	REVISED	12-31-62
LTR	REVISION RECORD	ECH

REQUIRED PER ASSEMBLY	DWG SIZE	NUMBER	NAME	REMARKS	ITEM NO.
				AMP INCORPORATED ALL RIGHTS RESERVED. AMP PRODUCTS COVERED BY PATENTS AND/OR PATENTS PENDING.	
				CUSTOMER COPY REFERENCE ONLY	
				MATERIAL AND FINISH	
				CLASS	
				WIRE - RANGE - INSULATION	
				TYPE "C" - P.I.D.G.	
				TOLERANCE EXCEPT AS NOTED	
				SCALE 2:1	
				LOC MC	
				NO. 59275	
				NAME	
				T HEAD ASSEMBLY MOD V	